



**ROLL OUT
RACKS**
ROLL OUT PALLETS SOLUTIONS

Waymarc

Roll Out Pallets Rack Mounted

CAPACITY : 1000 LBS UDL



BEFORE



Add one or more levels to your installations.

AFTER



Amongst the different elements of handling and storage equipment that we've developed, we have the Roll Out Pallet. This product responds to your reality by increasing execution speed all the while optimizing space and safety. Your inventory is a crucial element in the production process, and its importance is paramount. As a result, the Roll Out Pallet will easily give access to your material and greatly facilitate the gathering process and management of your inventory. Hence, the Roll Out Pallet units are durable and well suited to your handling and storage needs.



BASE



BASE WITH TOP PLATE



DOUBLEBASE WITH TOP PLATE

Standard base dimensions

36" DEEP		42" DEEP		48" DEEP	
WIDTH	DEPTH	WIDTH	DEPTH	WIDTH	DEPTH
24	36	24	42	24	48
30	36	30	42	30	48
36	36	36	42	36	48
40	36	40	42	40	48

More than one base are required for larger top plates.

Standard top plate dimensions

36" DEEP		42" DEEP		48" DEEP	
WIDTH	DEPTH	WIDTH	DEPTH	WIDTH	DEPTH
24	36	24	42	24	48
30	36	30	42	30	48
36	36	36	42	36	48
42	36	42	42	42	48
46	36	46	42	46	48
52	36	52	42	52	48

Top plate requiring two bases or more

36" DEEP		42" DEEP		48" DEEP	
WIDTH	DEPTH	WIDTH	DEPTH	WIDTH	DEPTH
94	36	94	42	94	48
106	36	106	42	106	48
142	36	142	42	142	48

More than one base are required for larger top plates.



Roll Out Pallets Floor Mounted

CAPACITY : 3000 LBS UDL

Hand picking is now made easier with the Roll Out Pallet installed directly on the floor and sliding the material out of the rack. Safe and efficient they roll on tracks installed on the floor so no one can take them out of the place. Made out of thick steel and heavy duty rollers, they withstand the harshest environments. The standard brake system securely holds the Roll Out Pallet in place when the lift is loading it. No more dangerous handling. Additionally, since you no longer need to crawl under to access your material, you can gain the extra space by lowering first level of beams.

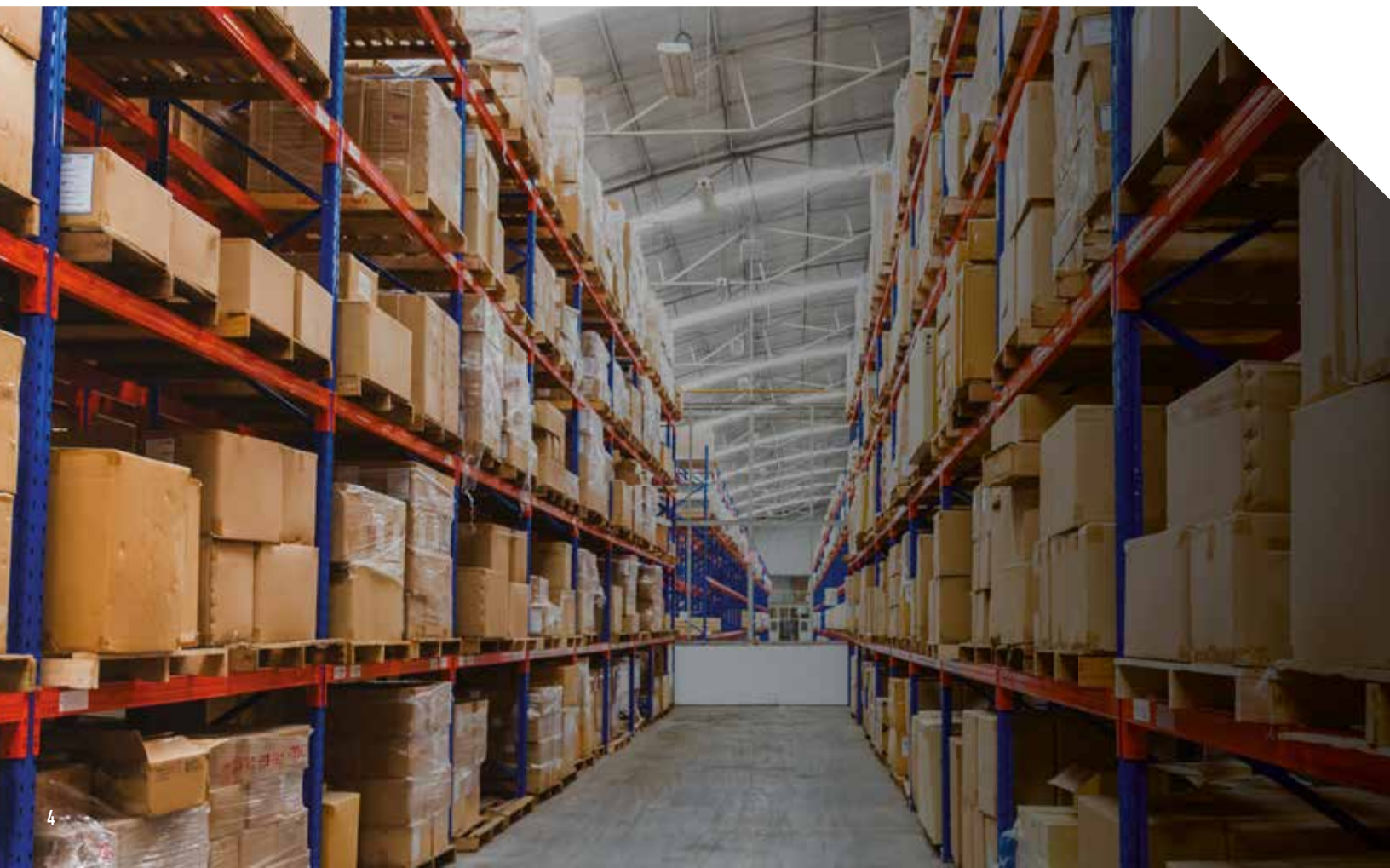

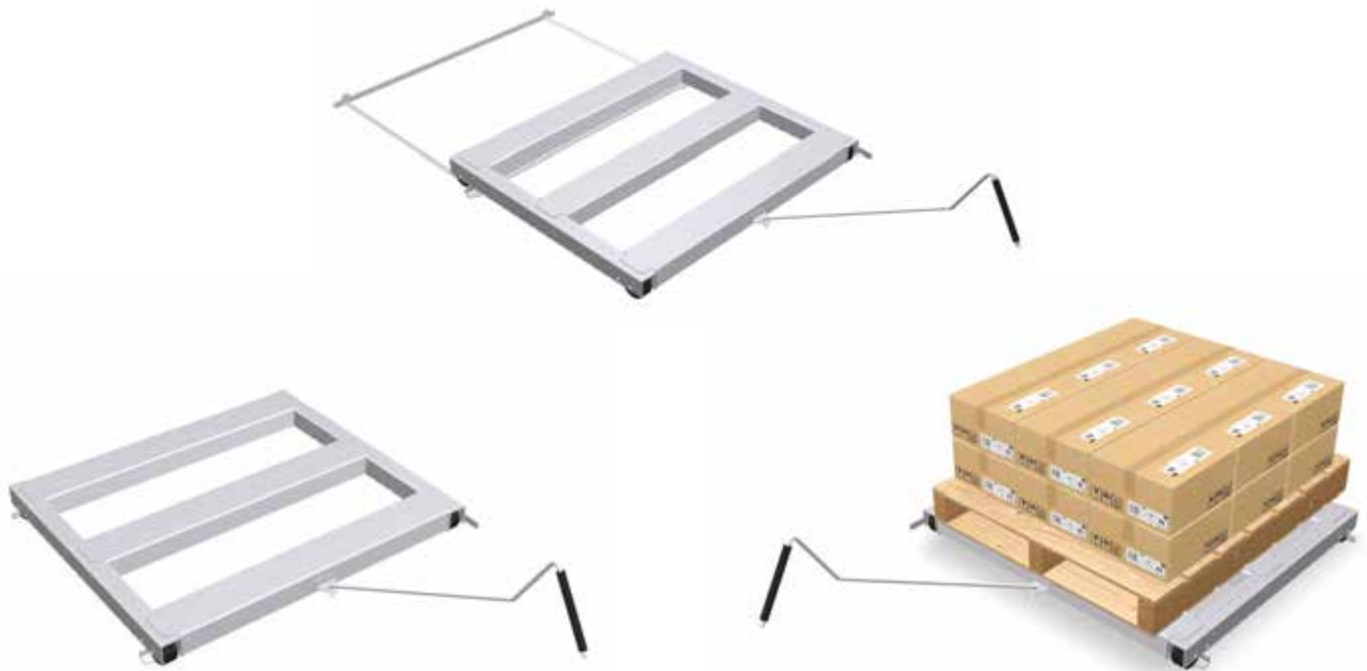

36" DEEP		42" DEEP		48" DEEP	
WIDTH	DEPTH	WIDTH	DEPTH	WIDTH	DEPTH
24	36	24	42	24	48
30	36	30	42	30	48
36	36	36	42	36	48
42	36	42	42	42	48
46	36	46	42	46	48
52	36	52	42	52	48

More than one base are required for larger top plates.
 Number of cross members can be modified to accommodate application.
 A full plate option is available.
 Optional back lips and side lips available

ROLL OUT RACKS

MANUFACTURED BY  **INDUSTRIUM**

REQUEST QUOTATION FOR ROLL OUT PALLET (RACK MOUNT)

Date: _____ / _____ / _____ Dealer: _____
Branch city/State: _____ Salesperson name: _____
Salesperson email: _____ Salesperson phone: _____
Customer name: _____ Customer city: _____

SPECIFICATIONS

QUANTITY: _____

Frame dimension: 40" wide x 42" deep 40" wide x 48" deep Other _____

Top plate dimension: 46" x 42" 42" x 42" 46" x 48" 42" x 48" Other _____

Top plate perforated Yes (Standard)

No holes, smooth

Top plate 1" side and 1" back lips

No side and back lips

Custom side height _____

Custom back height _____

Lock in (standard)

Lock in - Lock-out

Roll out extension: 75%

Capacity: 1000 lbs UDL

WILL BE INSTALLED ON

Frame dimension: _____ X _____ X _____ Length

Frame dimension: Box Step

- Recommandations:**
- 2 ROLL OUT PALLETS PER BAY, MINIMUM REQUIRED LEVEL CAPACITY: 5000 LBS
 - 3 ROLL OUT PALLETS PER BAY, MINIMUM REQUIRED LEVEL CAPACITY: 6000 LBS
 - OPENING ONE ROLL OUT PALLET AT A TIME
 - RACK BEAMS MUST BE BOLTED TO THE UPRIGHTS
 - UPRIGHTS PROPERLY ANCHORED TO THE FLOOR
 - FOLLOW RACK MANUFACTURER'S RECOMMANDATIONS AT ALL TIME

REQUEST QUOTATION FOR FLOOR MOUNTED MODULAR RACKING

Date: _____	Customer name: _____
Distributor: _____	Customer city: _____
Contact: _____	Email: _____
Phone number: _____	Other information: _____

GENERAL INFORMATION

QUANTITY: _____

Dimension: 46"W x 48"D 46"W x 42"D 42"W x 42"D 42"W x 48"D 40"W x 48"D

Cross member: 3 Standard Full Plate Other _____

Backstop: 1" 2" 3" Special No

Endstop: 1" 2" 3" Special No

Lock system: Yes No

Removable Pull Handle: 42" Standard 36" High Other

Roll out extension: 85%

Capacity: 3000 lbs UDL

OPENED

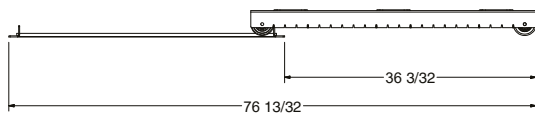

CLOSED

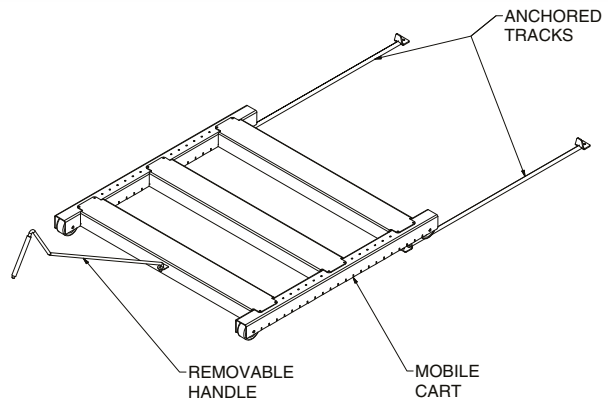
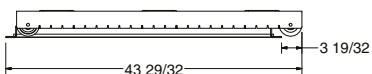



BRITISH COLUMBIA

Langley (604) 348-9182

ALBERTA

Edmonton (780) 453-2358
Calgary (403) 250-7881
Red Deer (403) 340-3599

SASKATCHEWAN

Saskatoon (306) 955-1430
Regina (306) 514-3665