

ROLL OUT RACKS

manufactured by INDUSTRIUM

Most popular for 20' , 24' and 40' material
Capacity starting at 3900 lbs.

100% accessible extended shelves



EFFICIENT
STORAGE
SYSTEMS



STRONG DEPENDABLE SOLUTION

Roll Out
Cantilever Rack

FOR MORE FLEXIBILITY, CHOOSE ROLL OUT RACKS STORAGE SYSTEMS



▲ Double-sided cantilever rack shown

BENEFITS

- Adjust arm levels to your needs
- Add or remove arms
- Minimize unused space between arm levels
- Increase racking height
- Large weight capacity per level
- Reduce storage area by 50%
- Reduce handling time by up to 80%
- Reduce risk of accidents
- Easy, safe Roll Out mechanism
- Improve inventory management
- Enhance accessibility for overhead lifting on all levels
- Enjoy easier storage

SPECIFICATIONS

- Racking height: 100", 124", 148" and 184"
- Arm width: 20", 24" and 36"
- Minimum space between arm levels: 5"
- Capacity per level starting at 3900 lbs.
- Fixed top capacity: 20,000 lb and over
- Roll Out Cantilever rack system is ideal for long and heavy materials (12', 20', 24' and 40') and can also be used for other types of material

OPTIONS

- Open extended shelf
- Full extended shelf
- Removable bottom Shelf
- Shelf separators: For storing different types of material on the same shelf

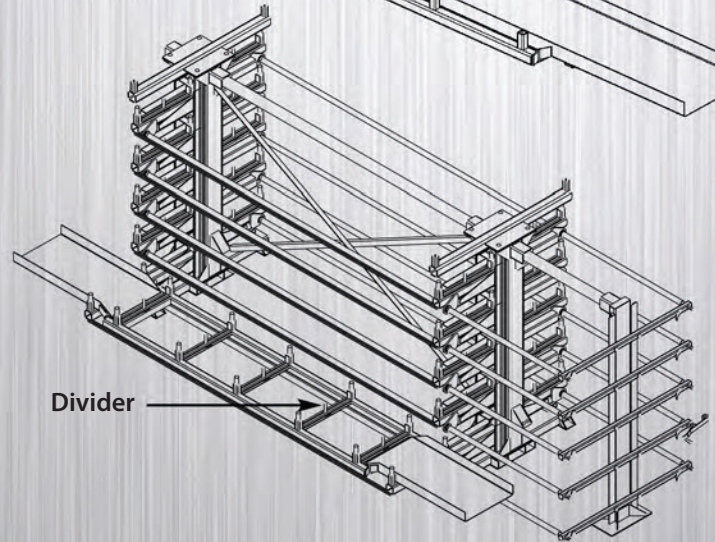
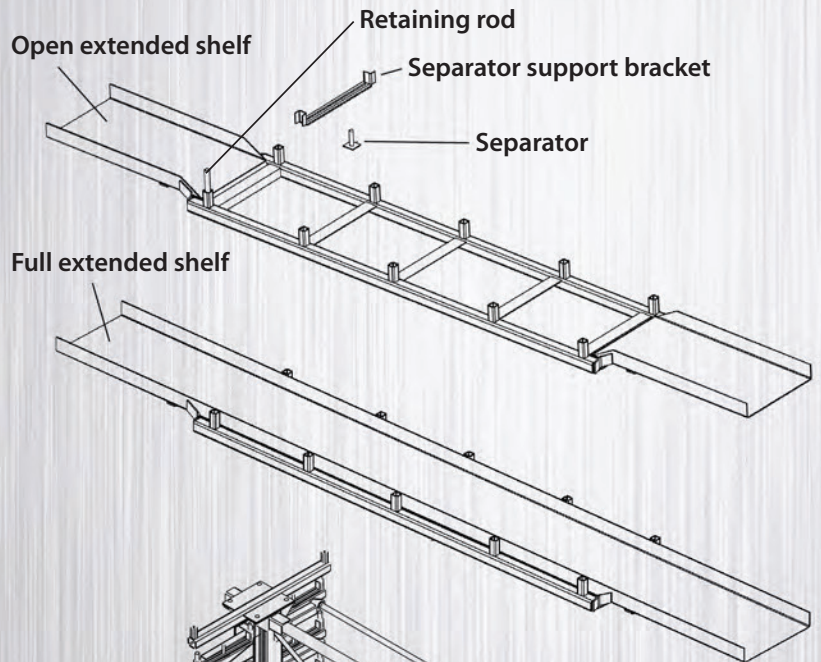

Single or double sided cantilever rack available

BRITISH COLUMBIA

Langley (604) 348-9182

ALBERTA

Edmonton (780) 453-2358
 Calgary (403) 250-7881
 Red Deer (403) 340-3599

SASKATCHEWAN

Saskatoon (306) 955-1430
 Regina (306) 514-3665

ROLL OUT RACKS

Fabriqué par/manufactured by INDUSTRIUM

REQUEST QUOTATION FOR MODULAR RACKING

Date : _____ Customer name : _____
 Distributor : _____ Customer city : _____
 Contact : _____ Email : _____
 Phone number : _____ Other information : _____

GENERAL INFORMATION

1) Modular racking type : Double Single
 2) Support column height : 100" 148" 184" (double only)
 124" Other : _____
 Quotation number Reserved for Roll Out Racks

LEVEL INFORMATION

1) Arm depth : 20" 24"
 30" 36"
 2) Arm level Capacity : _____
 3) Number of levels : _____
 4) Minimum spacing required between each level : _____

OPTIONS

1) Choice of shelf :
 Arms only
 Open extended shelf
 Quantity : _____
 Full extended shelf
 Quantity : _____
 2) Separator's support bracket :
 Separator's support bracket for open extended shelf
 Quantity : _____
 3) Separator :
 4" 7" 10" 13" 16" 19" 22"
 Total quantity : _____
 4) Full bottom separator (not illustrated)
 4" 7" 10" 13" 16" 19"

REPRESENTATION

