

# DOK-GUARDIAN™ Safety Barrier

*Prevent this from happening at your docks!*

Vacant loading docks create a dangerous 4' drop-off for dock personnel and material handling equipment. The brutal reality of this dangerous drop-off is often recognized only after it is too late. Rite-Hite has a full line of barrier products to make your loading docks safer.



Dok-Guardian Safety Barriers help meet the requirements of OSHA Regulation 1910.23 regarding "protection for wall openings and holes."



**RITE-HITE®**

# DOK-GUARDIAN™ Heavy-Duty SAFETY BARRIER

- Helps prevent fork trucks, pallet jacks, and pedestrians from falling off a loading dock.
- Manually positioned barrier easily fits across openings up to 16' (4.9m) wide.
- Simple, easy-to-use safety solution for almost any loading dock.
- Barrier heightens dock drop-off awareness.
- Warden™ guards provide excellent door track protection.

Barrier will stop a 10,000-pound (4536kg) fork truck traveling up to 4 miles per hour (6.44kph) with little or no damage to the safety barrier.



Unique Warden "pocket" design helps keep barrier positively stored and out of harm's way.

## Specifications:

- 48" (1.2m) tall 1/4" (6.4mm) steel Warden™ door guards (Roller side and Latching side)
- Warden™ guards to be painted safety yellow
- Utilizes (6) 3/4" (19mm) x 5 1/4" (133.4mm) anchors each side (included)
- 5/8" (15.9mm) x 16" (406mm) x 16" (406mm) base plate (Roller side)
- 5/8" (15.9mm) x 16" (406mm) x 14" (355mm) base plate (Latching side)
- Curtain to be red PVC coated fiberglass mesh with three heavy duty polyester safety restraint straps
- Proper setback from the edge of the dock will be determined by the width of the Dok-Guardian
- 1-year warranty

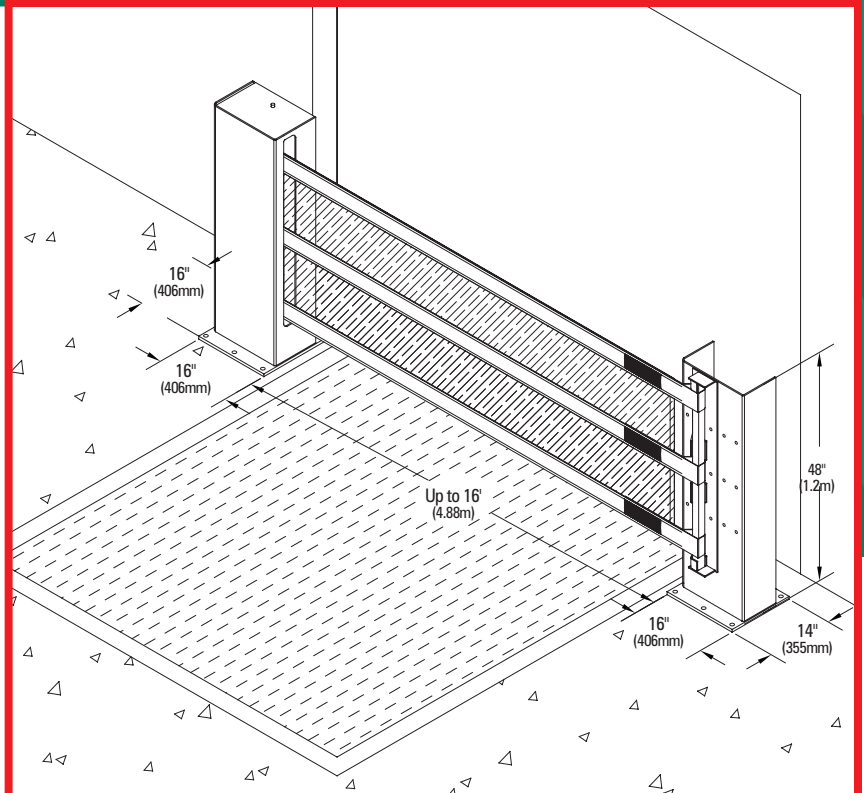

# DOK-GUARDIAN™ Light-Duty SAFETY BARRIER



- Helps prevent carts, pedestrians, and non-motorized lift trucks from falling off the dock.
- Manually positioned barrier easily fits openings up to 16' (4.9m) wide.
- Barrier will stop a 1,000-pound (453kg) load traveling up to 4 miles per hour (6.44kph) with little or no damage to the safety barrier.
- Warden™ guards provide door track protection.

## Dok-Guardian Safety Barrier Operation



1. To activate, dock personnel extends barrier across the opening.



2. Latching system ensures safe, strong barrier protection.



3. To store, remove barrier from the latching bracket and walk barrier to non-active position. Barrier automatically retracts.

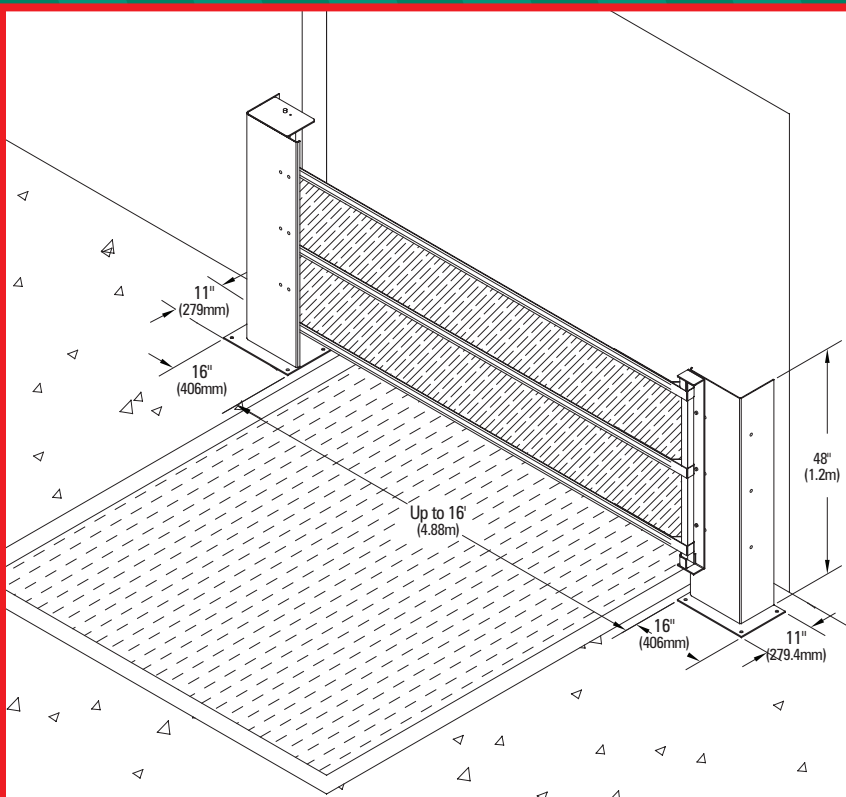

## Specifications:

- 48" (1.2m) tall 3/16" (4.8mm) steel Warden™ door guards (Roller side and Latching side)
- Warden™ guards to be painted safety yellow
- Utilizes (4) 1/2" (12.7mm) x 5 1/4" (133.4mm) anchors each side (included)
- 1/4" (6.4mm) x 16" (406mm) x 11" (279mm) base plate (Roller side)
- 1/4" (6.4mm) x 16" (406mm) x 11" (279mm) base plate (Latching side)
- Curtain to be yellow PVC coated fiberglass mesh with three polyester safety restraint straps
- Proper setback from the edge of the dock will be determined by the width of the Dok-Guardian
- 1-year warranty

